

D2D160-BE02-11

AC centrifugal fan with housing (without flange)

forward curved, dual inlet



Nominal data

Type	D2D160-BE02-11	
Motor	M2D074-FA	
Phase		1~
Nominal voltage	[V]	380
Frequency	[Hz]	50
Type of data definition		ml
Valid for approval / standard		CE
Speed	[min ⁻¹]	2700
Power input	[W]	700
Current draw	[A]	1.8
Motor capacitor	[μF]	10
Capacitor voltage	[VDB]	400
Min. back pressure	[Pa]	200
Max. ambient temperature	[°C]	40
Air flow	[m ³ /h]	1195
Back pressure	[Pa]	200
Sound pressure level	[dB(A)]	64

ml = max. load · me = max. efficiency · rfa = running at free air · cs = customer specs · cu = customer unit
Subject to alterations

D2D160-BE02-11

AC centrifugal fan with housing (without flange)

forward curved, dual inlet

Technical features

Leakage current	< 0,75 mA
Size	160 mm
Operation mode	S1
Mounting position	Any
Direction of rotation	Counter-clockwise, seen on rotor
Insulation class	"F"
Cable exit	Axial
Condensate discharge holes	None
Bearing-motor	Ball bearing
Mass	5.7 kg
Housing material	Sendzimir galvanized sheet steel
Material of impeller	Sendzimir galvanized sheet steel
Motor suspension	Motor mounted with anti-vibration on both sides
Motor protection	Thermal overload protector (TOP) wired internally
Product conforming to standard	CE; EN 60335-1
Surface of rotor	Partially cast in aluminium
Type of protection	IP 20
Protection class	I
Approval	CCC; GOST

D2D160-BE02-11

AC centrifugal fan with housing (without flange)

forward curved, dual inlet

Product drawing

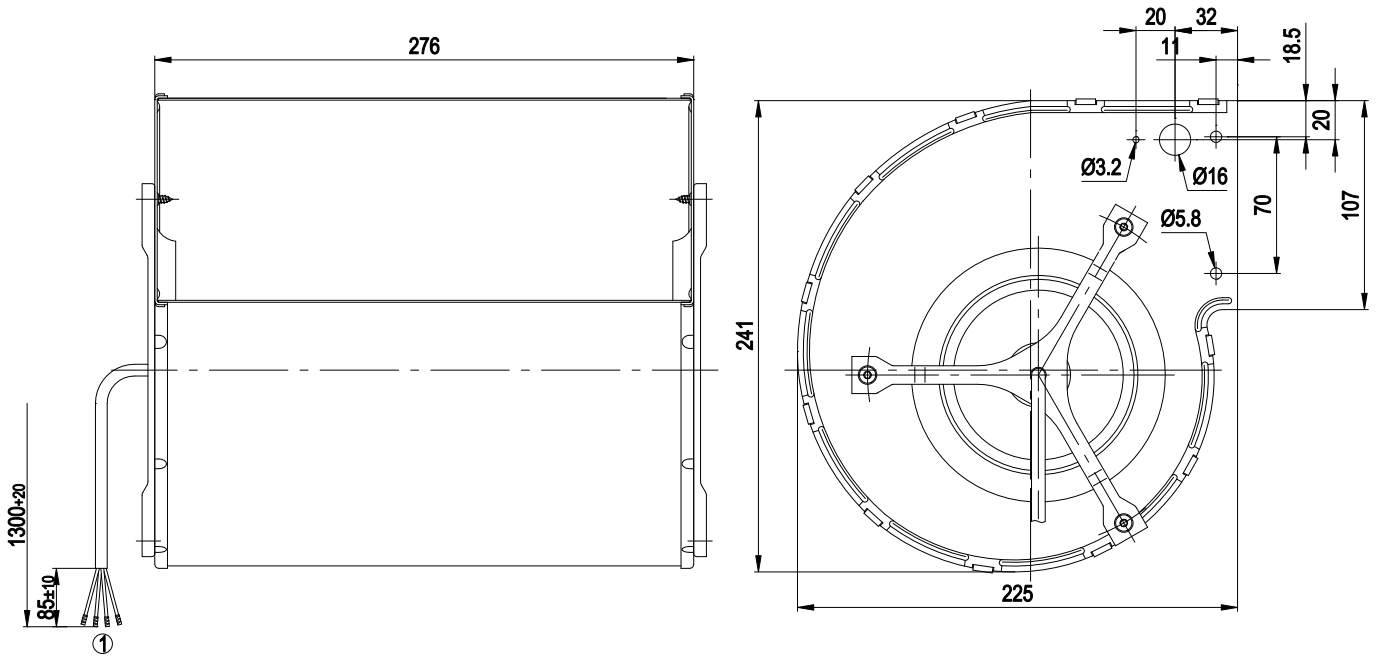

1 Connection line ETFE AWG 20, 4x brass lead tips crimped

Connection screen

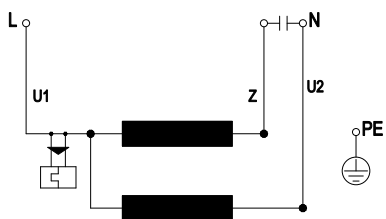

U1	blue	Z	brown	U2	black
PE	green/yellow				